

IBS Pulley Design

Our engineers have been designing pulleys for over 40 years, and we have supplied pulleys to some of Australia's largest companies including Rio Tinto and BHP.

At IBS, we utilise Finite Element Analysis software to ensure our pulleys meet the most stringent design criteria. Coupled with our experience fabrication and quality control, we can ensure our pulleys can meet your demands. Using our fabrication partners in Australia and Asia, our pulleys can be supplied in the timeframe you require and within your budget. Our pulleys can be designed using locking elements, fully welded hubs, and many other options to suit your application. From $\text{\O}250\text{mm}$ to over $\text{\O}1.5\text{m}$ and over 2m wide, we can design and supply drive, tail, bend and counter weight pulleys to suit your requirements.

Whether it is for breakdown replacement, inventory spares or to be incorporated into new equipment, IBS has the solution for you.

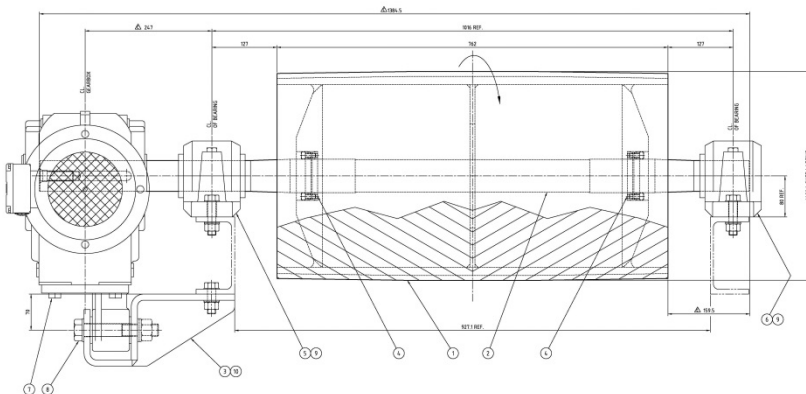
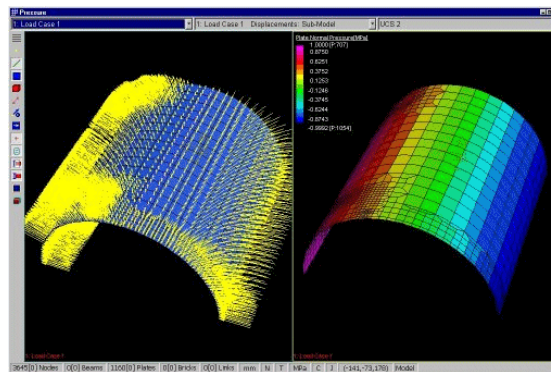

Integrated Bulk Systems (IBS) Pty Ltd

ABN: 22 164 393 873

Unit 205/75 Tulip St, Cheltenham

Victoria, 3192, Australia

Ph: +61 3 9585 6391

Fax: +61 3 9585 4349

E-mail: info@integratedbulksystems.com.au

Web: www.integratedbulksystems.com.au

*... Ask us how we can improve
your processes today*